



國立中央大學

NATIONAL CENTRAL UNIVERSITY

Office of International Affairs

2019 Spring

International Degree Student

Student Handbook

Content

PART 1	Important Dates in February, 2019	2
PART 2	Preparation and Arrival	4
	✧ Visa & ARC	
	✧ Money exchange	
	✧ Cell phone (Pre-paid card)	
	✧ Requiring format of ID photo	
	✧ Buddy system	
	✧ NCU address and transportation	
PART 3	Orientation	10
PART 4	Tuition and Miscellaneous Expenses	17
	✧ Tuition and credit fee	
	✧ Standard for dormitory fee	
	✧ Other fees	
PART 5	Insurance	21
PART 6	Check List for Registration	23
PART 7	Other Information	25
PART 8	Appendix	30
	✧ Location	
	✧ Units	
	✧ Building symbols	
	✧ Other units you may know in Taiwan	

PART 1: Important Dates in February, 2019

Date	Event
February 4 th – 8 th	<ul style="list-style-type: none"> ● Chinese New Year ● OIA will be closed during this period of time
February 11 th -15 th	<ul style="list-style-type: none"> ● Registration & Orientation Week
February 11 th -13 th	<ul style="list-style-type: none"> ● International students arrival ● Dormitory or Temporary dorm check-in ● Find off-campus housing or accommodation ● Temporary dorm (Student Dormitory) check-in on Feb. 11th and check out on Feb. 13th
February 14 th	<ul style="list-style-type: none"> ● Registration (in the morning) ● Freshman Session (in the afternoon)
February 15 th	<ul style="list-style-type: none"> ● Health examination
February 17 th	<ul style="list-style-type: none"> ● Tuition payment deadline
February 18 th (Monday)	<ul style="list-style-type: none"> ● Classes begin
February 13 th – 27 th	<ul style="list-style-type: none"> ● Online course selection (Add & Drop)



PART 2: Preparation and Arrival

I. Visa & ARC:

Although some countries' citizens are allowed to enter Taiwan without a visa, a **Resident Visa or Visitor visa is required** for those who intend to study or work in Taiwan. If students come to Taiwan without a visa and want to apply for one, they will have to leave Taiwan and apply a resident/visitor visa overseas. It may cost a lot of money and time. In addition, if students hold a visitor visa, he/she cannot apply ARC with visitor visa, he/she has to go to Bureau of Consular Affairs in Taipei to apply a resident visa first. After getting resident visa, he/she can apply ARC (Alien Resident Certificate) at immigration agency.

- Resident visa holders should apply for ARC at local service center of National Immigration Agency **within 15 days after arrival**.

ARC applying procedures for students enter Taiwan with different types of visa:

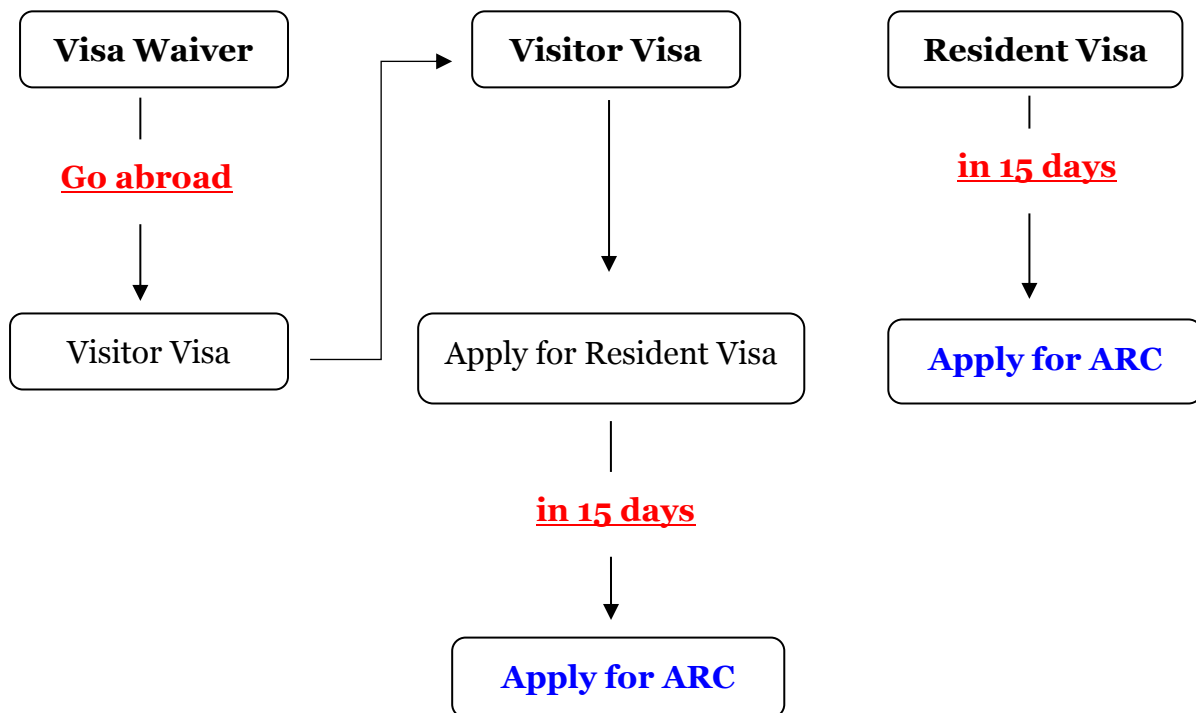

● **Apply for Resident Visa:**

✧ Required documents **in original & photocopy**

- ✓ Application Form
- ✓ Student ID Card
- ✓ Two photos (refer to page 8)
- ✓ Passport
- ✓ Admission Acceptance Letter
- ✓ Scholarship Certificate
- ✓ Financial Statement, which declares the account could be withdrawn in Taiwan (with amount approximately NT\$300,000 to NT\$500,000) and is verified by Taipei Economic and Culture Office either domestic or abroad.
- ✓ Original Diploma & Transcript (with verification by Taipei Economic and Culture in foreign country)
- ✓ Proof of Enrollment in English (Apply from Registry Office with NT\$10)
- ✓ Tuition Receipt
- ✓ Health Certificate
- ✓ Fee: NT\$3,000 (NT\$5,280 for U.S citizens)

✧ Where to apply :

Overseas: Please refer to <https://www.boca.gov.tw/lp-191-2.html>

Taiwan: Taipei Bureau of Consular Affairs (BOCA) (<http://www.boca.gov.tw>)

Add.: 3-5 Fl, No. 2-2, Section 1, Jinan Rd, Taipei City

Tel: 02-23432888

Transportation: Taipei MRT to NTU Hospital Station



BOCA - The Bureau of Consular Affairs

MOFA - The Ministry of Foreign Affairs

NTUH - National Taiwan University Hospital

LY - The Legislative Yuan Republic Of China

MOE - Ministry Of Education

SCHOOL - Kai-Nan High School

● **Apply for ARC :**

✧ Required documents **in original & photocopy :**

- ✓ Multiple-Purpose Application Form for Foreigners
- ✓ Student ID Card (if applicable)
- ✓ One photo (refer to page 8)
- ✓ Passport
- ✓ Resident Visa
- ✓ Proof of Enrollment in English (Apply from Registry Office with NT\$10)
- ✓ Receipt of Tuition Payment
- ✓ Housing contract or dormitory certificate
- ✓ Old ARC (if applicable)
- ✓ Fee: NT\$1,000

✧ Where to apply :

National Immigration Agency Taoyuan City Service Center

Add.: 1F, No.106, Xianfu Rd., Taoyuan City

Tel: 03-3314830 · 03-3310409 · 03-3318243

Transportation: Taoyuan Bus #1



II. Money Exchange

If you are not sure whether the currency in your country can be exchanged into NT Dollars, you should exchange it for U.S. Dollars in your home country first and then change into NT Dollars at the Taiwan Taoyuan International Airport.

III. Cell Phone (pre-paid card)

1. System used in Taiwan: GSM System

2. **Where to get pre-paid card: Taiwan Taoyuan International Airport:** Purchasing a cellphone (or a phone card) upon arrival is **strongly recommended**. A cellphone is the ideal line of communication should emergencies arise. **Acquiring a phone prepaid card at the airport will be a lot easier and quicker** than doing it after arriving campus as the only identification you need is a passport. For more information, please visit: http://www.taoyuan-airport.com/english/store3_1/1106

IV. Required Format of ID Photo

Photos are required for school registration and ARC, NHI card application. Therefore please prepare some photos in advance. Here's the format for photo:

- Should be identifiable, shouldn't be modified or composed
- Color photo with white background
- Be taken in six months
- 4.5cmx3.5cm
- From the top of the head to the chin: between 3.2cm to 3.6cm

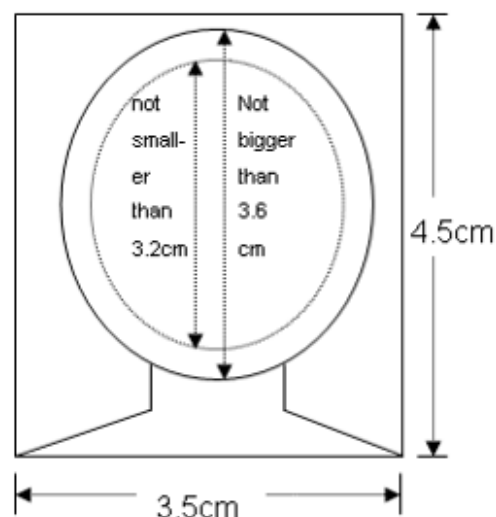

V. Buddy system

Buddies (Taiwanese students) will be assigned to help incoming students when they arrive in Taiwan. During the orientation week, buddies will help on registration, payment, course selection, health examination and etc.

VI. Transportation from Taiwan Taoyuan International Airport to NCU

- Address: No. 300, Zhongda Rd., Zhongli District, Taoyuan City 32001, Taiwan
地址：桃園市中壢區中大路 300 號
- The closest airport to NCU is Taiwan Taoyuan International Airport.
(<https://www.taoyuan-airport.com>)
- Transportation
 - Taxi (NT\$500~1000): It takes approximately 30 minutes.
 - City Bus (NT\$54): From airport→Zhongli Main Station (take bus No.132) → NCU
 - Metro+ Taxi /Bus: From airport→ HSR Metro station (by Metro)
HSR station → NCU (by Taxi/by bus 172)
 - For more information please refer to:
http://www.ncu.edu.tw/en/visitors/public_transportation

PART 3: Orientation

※ All students must arrive no later than **February 13th, 2019.**

Date	Item	Task
Feb.11 th - 13 th Mon. - Wed. 09:00-17:00	Dormitory & Temporary Dorm Check-in	Please go directly to the dormitory or temporary dorm with student's passport and approved dormitory application form. If you have reserved to stay in off-campus accommodation, please also go directly to the place you have reserved.
Jan. 30 th - Feb. 17 th Thur. - Sun.	Payment	<p>The payment for the tuition and miscellaneous fee should be finished before Feb. 17th (Sun.)</p> <ol style="list-style-type: none"> 1. Pay for the tuition at the convenience store (FamilyMart, 7-11) 2. If students fail to pay before Feb. 17th, they will be asked to apply for deferral of registration before Feb. 17th. 3. Keep the receipt 4. Preparing all the required documents for registration on Feb. 14th. 5. Submit the COPY of the receipt to the OIA on Feb. 14th
Feb. 13 th Wed.	Apartment search & temporary dorm check-out	Temporary dorm check-out on Feb. 13 th before 11:00am.

<p>Feb. 1st - 15th</p>	<p>Online Registration</p>	<p>For your right and obligations, student should fill out the required personal information online. Please make sure your English name shown on the site is the same as the one in your passport.</p> <div style="border: 1px solid black; border-radius: 15px; padding: 5px; text-align: center; margin-bottom: 10px;"> Register online https://tarot.cc.ncu.edu.tw/UnixAccount/enableaccount.php </div> <p style="text-align: center;">↓</p> <p style="text-align: center;">ID No. – your student ID No. Password – set up by yourself and remember it Wait for 5 minutes</p> <div style="border: 1px solid black; border-radius: 15px; padding: 5px; text-align: center; margin-bottom: 10px;"> Get the email account from Computer Center </div> <p style="text-align: center;">↓</p> <div style="border: 1px solid black; border-radius: 15px; padding: 5px; text-align: center; margin-bottom: 10px;"> Fill in your Personal Information https://portal.ncu.edu.tw/login </div> <p style="text-align: center;">↓</p> <div style="border: 2px solid black; border-radius: 15px; padding: 5px; text-align: center; margin-bottom: 10px;"> Completed </div>
<p>Feb. 15th Fri. 08:00-10:30</p>	<p>Health Examination (Resident Visa holders)</p>	<p>Location: Ten-Chan Hospital</p> <ul style="list-style-type: none"> ● Please do not eat or drink 8 hours before the examination ● Fill out the “NCU Student Health Form” ● Students who wish to ride on the school shuttle (one time only) are to meet at OIA at 8:00 am. ● Fee: NT650-800 ● Every student needs to complete the health examination, otherwise you will not get the student ID card. ● If you are not available on Feb 15th, you can go to Ten-Chan General Hospital to do health examination by yourself before Feb 18th, and the fee might be different. <p>http://www.tcmg.com.tw/eng/index_en.php?Key=3</p>

Registration (OIA → Department → Registry Division)

**Feb. 14th
Thur.
09:00-12:00**

OIA Registration
(Auditorium B1)

**Location: Multimedia Room, Grand Lecture Hall
(Auditorium B1)**

Submit one copy of the following documents and bring the original copy for confirmation:

- **You MUST have a copy of each document ready before registration.**
- 1. Graduation certificate and transcript that have been verified by Taiwan Embassy Office Abroad (Original and one copy)
- 2. Passport (Original and one copy)
- 3. Visa with the arrival stamp (Original and one copy)
- 4. International student information form (Original)
- 5. Authorization for emergency treatment (Original)
- 6. Personal information collection agreement (Original)
- 7. Payment receipt for Spring semester 2019 (one copy)
- 8. Housing contract/ Accommodation certificate (one copy)
- 9. Alien Resident Certificate (ARC), if applicable (one copy)
- 10. National Health Insurance (NHI) Card, if applicable (one copy)
- 11. Post office account book, if applicable (one copy)

Note

- All original documents will be returned after the registration. You should notice and double check with your own original documents before leaving the office. You must assume full responsibility of the loss of the original documents.
- Please complete International Student Information Form , Authorization for emergency treatment and Personal information collection agreement before come to OIA registration.

Feb. 14th Thur. 09:00-12:00 13:00-14:00	Department Registration	<ul style="list-style-type: none"> ✧ Get course list or other notifications from your department. ✧ Please submit: <ul style="list-style-type: none"> ● Registration form (with one photo) ● The original letter of acceptance ● Original highest academic diploma ● Original highest academic transcript ● Copy of the graduation certificate and transcript that have been verified by Taiwan embassy office abroad. <p><i>*Note*</i></p> <ul style="list-style-type: none"> ● Your registration form should be stamped by your department. ● All original documents will be returned after examination. You should notice and double check your own original documents before leaving the office. Students must assume full responsibility of the loss of the original documents.
Feb. 14th Thur. 09:00-12:00 13:00-14:00	Registry Division Registration	<p>After Department Registration, you should submit the following documents to Registration Division (3rd floor, Administrative Building):</p> <ul style="list-style-type: none"> ● Registration form with your identification documents, a photo & stamp from department. ● Copy of the graduation certificate and transcript that have been verified by Taiwan embassy office abroad. <p><i>*Note*</i></p> <ul style="list-style-type: none"> ● Your registration form should be stamped by your department. ● All original documents will be returned after examination. Students should notice and double check your own original documents before leaving the office. Students must assume full responsibility of the loss of the original documents.
Feb. 14th Thur. 14:00-17:00	Freshman Session	<p>Location: Multimedia Room, Grand Lecture Hall (Auditorium B1)</p> <ul style="list-style-type: none"> ● Admission Process ● Introduction of units at NCU ● VISA application / ARC application ● Life around NCU

Feb. 18th Mon.	All students arrive	Classes begin.
Feb. 18th Mon.	Library Registration	<p>Before using the library properties, make sure you fully understand the regulations before confirming your e-mail address. Sign "The Statement of Patron's Privileges."</p> <p>https://www2.lib.ncu.edu.tw/pbatch/</p>  <p>*You will need to complete this procedure in order for your card to work.</p>

Course Selection		
Feb. 13th – 27th	Course Selection	<ul style="list-style-type: none"> ● Add & Drop courses online https://cis.ncu.edu.tw/Course/main/news/announce ● System maintenance from 7am to 9am every day. The service will be stopped temporarily. ● Do not take two or more courses that are offered at the same time, otherwise, you will fail in adding or dropping courses. ● If the classes need course code number for selecting the course, please ask your course instructor for the “code number”.
Mar. 5th – 7th Tue. -Thur.	Manual Course Selection (costs NT\$100 for each handling fee)	<ul style="list-style-type: none"> ● Add /Drop the course online first, then print the application form, get the signature/stamp/approval from the teacher (lecturer) and department, then submit the form to the Curriculum Section, 3rd floor of Administration Building. ● NCU Course Schedule Planning System : https://cis.ncu.edu.tw/Course/main/news/announce
Mar. 5th – 8th Tue. - Fri.	Course Selection Reconfirmation	Students go to course selection system to confirm course selection list.
Mar.14th – 25th. Thur.- Mon.	To pay the credit fee	Students can download the bill in Portal and pay it in the convenient store (FamilyMart, 7-11).
Apr. 1st – May 17th Mon.-Fri.	Course Withdrawal	<ul style="list-style-type: none"> ● Applications for Course Withdrawal (ONLY ONE Course) ● Withdraw the course online first, then print the application form, get the signature/stamp/approval from the teacher (lecturer) and department, then submit the form to the Curriculum Section. ● NCU Course Schedule Planning System : https://cis.ncu.edu.tw/Course/main/news/announce

Student ID Card

After going through the registration procedure above (OIA and Department, Register online, payment, examination of health status), you will receive your student ID card. After students complete the procedures above, please collect it directly from the Registry Division.

PART 4: Standard for Tuition and Miscellaneous Expenses

I. Tuition and Credit Fee

	College/ Department/Institute	Tuition/ Sundry Expenses	Credit Fee
Undergraduate	Liberal Arts (Expect Inst. of Art)	NT\$ 45,691	NT\$2,000/credit
	Science & Earth Science	NT\$53,183	NT\$2,220/credit (except Math Depart. NT\$2,100/credit)
	Engineering & Electrical Engineering (include Inst. of Information Management & Industrial Management & Art)	NT\$52,668	NT\$2,220/credit
	Management (except Information Management & Industrial Management)	NT\$46,091	NT\$2,040/credit
	College/ Department/Institute	Tuition/ Sundry Expenses	Credit Fee
MASTER & PHD	Liberal Arts (except Inst. of Art) Hakka Studies	NT\$22,200	NT\$3,140/credit
	Science & Earth Science	NT\$25,700	NT\$3,140/credit
	Engineering & Electrical Engineering (include Inst. of Information Management & Industrial Management & Art)	NT\$26,620	NT\$3,140/credit
	Management (except Information Management, Engineering Management)	NT\$22,500	NT\$3,140/credit
	MASTER	International Environment Sustainable Development	NT\$12,000

II. Other fees

Item	Expense
School Group Accidental Insurance	NT\$209 / semester
Health Examination	NT\$1,000~2,000 Only for first semester enrollment
Internet Internship Fee	NT\$600 / semester
Dormitory Internet (alternative fee)	NT\$800 / semester
Dormitory Air conditioner (alternative fee)	NT\$500 / card Depends on the usage
Cathay Insurance	NT\$6,000 Two Semesters
National Health Insurance	NT\$4,494/semester Starting from the second semester
Dormitory Deposit	NT\$1,000 Once only during the enrollment of the first semester
ARC (Alien Resident certificate) application	NT\$1,000/year
Beddings Set (alternative fee)	NT\$1,500 Only for the first semester
Food (alternative fee)	NT\$50-150/meal
Transportation (alternative fee)	NT\$18/NT\$36 (bus) NT\$89 (train to Taipei) NT\$155 (HSR to Taipei)

III. Standard for Dormitory Fee

Dormitory		Fee
Graduate Dormitory	Male Graduate Dormitory	Fall Semester NT\$8,330 (5 months) Spring Semester NT\$11,660 (7 months)
	Female Dormitory 14	First Semester NT\$7,730 (5 months) Spring Semester NT\$10,620 (7 months)
	Male Dormitory 3	NT\$4,710 /semester
Undergraduate Dormitory	Male Dormitory 7	NT\$4,940 /semester
	Male Dormitory 9B	NT\$6,620 /semester
	Male Dormitory 11	NT\$4,910 /semester
	Female Dormitory 1	NT\$5,060 /semester
	Female Dormitory 4	NT\$6,330 /semester

More details about NCU dormitory rating, please refer to:

<https://in.ncu.edu.tw/~ncu7221/OSDS/table/%E5%AD%B8%E7%94%9F%E5%AE%BF%E8%88%8D%E6%94%B6%E8%B2%BB%E4%B8%80%E8%A6%BD%E8%A1%A8NCU%20Dormitory%20Rating%20List-1070717.pdf>

PART 5: Insurance

I. Safety Insurance (Student insurance for NCU students)

All the NCU students have Safety Insurance and pay it with tuition bill.

II. National Health Insurance (NHI)

Students with Valid ARC will be registered in the NHI program upon living in Taiwan for 6 months (6 months of continuous residence in Taiwan or with one trip abroad not exceeding 30 days when the actual residency period of 6 months is reached after the days abroad have been deducted).

When students are qualified to enroll NHI, OIA will apply it for international students, and students have to pay the fee with tuition bill.

※ When you just arrived in Taiwan, you are unable to apply for NHI. Instead, you will have Cathay insurance for the first year in NCU.

III. Cathay Insurance (Group insurance for international students)

For international students who do not have National Health Insurance (NHI). With Cathay insurance, you can go to the clinic or hospital and pay the whole fee by yourself first. The coverage of reimbursement is as following:

Item	Insured Value	Remark
Clinic	Maximum of reimbursement NT\$1,000 (per day/visit)	If the insured suffers an illness or injury and receives treatment at a hospital as an inpatient, the company will reimburse the following expenses incurred.
Hospitalized	Maximum of reimbursement NT\$1,000 (per day)	The payment of benefit shall not exceed the limit of NT\$120,000 (per hospitalization)

Please be noted that the payment of reimbursement for Outpatient/Emergency treatment shall not exceed the limit of **NT\$1,000 (per visit)**.

Please submit the following documents to OIA for reimbursement application:

- A. The receipt
- B. The medical certificate (apply from the hospital)
- C. Post office account book、Passport、ARC (only for first time application)
- D. Application form (available at OIA)

OIA will apply the insurance medical subsidy by submitting the documents above to Cathay insurance company.

PART 6: Check List for the Registration

Please confirm personal information and submit the documents while you come to registration.

OIA Registration

- Graduation certificate and transcript that have been verified by Taiwan Embassy Office Abroad (Original and one copy)
- Passport and Visa **with the arrival stamp** (Original and copy)
- International student information form, Authorization for emergency treatment and Personal information collection agreement (Original)
- Tuition Payment receipt (copy)
- Housing contract/ Accommodation certificate (copy)
- ARC, NHI Card, Post office account book, if applicable (copy)

Department Registration

- Registration form (with one photo)
- The original letter of acceptance
- Original highest academic diploma
- Original highest academic transcript
- Copy of the graduation certificate and transcript that have been verified by Taiwan embassy office abroad

Registry Office Registration

- Registration form with your identification documents, a photo & stamp from department.
- Copy of the graduation certificate and transcript that have been verified by Taiwan embassy office abroad.

- ※ Please make the copies of your documents by yourself at the convenient store first, including the NCU payment receipt.
- ※ To avoid your registration be delayed, please check and bring all the documents above before you come to register.

PART 7: Other Information

I. Student Opinions Boxes

If you have any comment, you could contact with Division of International Administrative Affairs, Office of International Affairs directly through emailing to wandahuang@ncu.edu.tw or ncuoia@ncu.edu.tw.

Other ways for delivering your comments are listed as follows:

- NCU Suggestion Box:

http://ncusec.ncu.edu.tw/suggestion_box/advice_form.php



The screenshot shows a web form titled "校長意見信箱 Suggestion Box". The form includes the following fields and options:

- *為必填欄位: (Required fields)
- *Email: [Text input field]
- *身分: (Identity)
 - 學生(Student)
 - 教職員(Faculty and Staff)
 - 校外人士(Visitor)
- *姓(Last Name): [Text input field] *名(First Name): [Text input field]
- 連絡電話(Contact Number): [Text input field]
- *陳情主旨(Subject)限50字以內: [Text input field]
- *陳情內容(Message): [Large text area]

- Vice President for International Affairs E-mail:

ncu57080@ncu.edu.tw / hhsu@ncu.edu.tw

- Boxes for Student Survey and Feedback:

Students' opinion can be provided through this link: <http://140.115.184.179/ncuCareYou/login.php?language=en>. Office of Student Affairs will reply general comments within 3 working days. If your case could not be replied within the deadline, OSA will explain the reasons to you, and will reply within 7 working days. If your special case require further discussion, regulation amendment or complicated situation, OSA will reply to you about the current procedure within 7 working days, they shall follow up with your case and reply to you no more than 30 days.



II. Gender Equity Education Committee

The Gender Equity Education Committee of NCU endeavors to achieve campus-wide gender equity in various fields to cultivate NCU faculty, staff and students and thus prevent gender bias and sexual discrimination.

✧ The Aims of the Gender Equity Education Committee of NCU

- To coordinate and integrate related resources of the different offices of NCU to design and implement a gender equity education plan and review its practical performance.
- To plan and organize gender equity education activities for faculty, staff, students, and their families.
- To develop and promote gender equity education courses, teaching and performance review.
- To draft regulations for gender equity education, prevent incidents of sexual assault and sexual harassment on campus, establish a response system, and coordinate related resources.
- To investigate and deal with issues about gender equity education as well as complaints about sexual harassment and employment gender equity.
- To plan and establish a secure campus of gender equity.
- To promote family and social education about gender equity in the community around NCU.
- Other issues about gender equity in NCU or in the community.



III. Weather

Taiwan is located at the subtropical climate area. The temperature in Zhongli area is 28-35°C in summer, and about 8-15°C in winter. Spring and Fall are the most enjoyable seasons during the year, but the “Plum Rain Season” lasting for about one month in May and June is an exception.

Website of Central Weather Bureau: <https://www.cwb.gov.tw/eng/index.htm>

IV. Food

- ✧ Campus Restaurant:
 - The 7th Canteen & the 9th Canteen: Taiwanese style local food, fruit and drinks are provided. Students can also use these areas for gathering, discussion and exchange ideas.
 - Mos Burger: Delicious fast food is provided
 - LALA Kitchen: New Orleans food
 - Convenient Store: Various food, drinks and dessert are available here
 - Coffee Stand: coffee, drinks, waffle and sandwich are provided
- ✧ Restaurant out of Campus

When it comes to the satisfaction of daily needs, in addition to the many cafeterias on campus, you may want to check out the Midnight Snack Alley and Back Gate area, both located right outside the university parameter, where many faculties and students enjoy alternative food choices.

V. Transportation

- ✧ Transportation to Zhongli Downtown (near Zhongli Train Station):
 - Bus: It is available on the campus, costing about NT\$18.
- ✧ Transportation to Taipei:
 - Bus: It costs about NT\$80 from Zhongli Downtown directly to Taipei (near Taipei Train Station).
 - Train: The fare varies depending on different kinds of train. It costs NT\$57-NT\$89.
 - High Speed Rail: It costs about NT\$155 to Taipei Main Station.
- ✧ You Bike: There are You Bike station in/near the campus, you can rent the bike around Taoyuan city.
- ✧ Information about public transportation
 - Taoyuan City Bus Time System: <https://ebus.tycg.gov.tw/NewTaoyuan/Dybus.aspx>
 - Taoyuan Metro: <https://www.tymetro.com.tw/tymetro-new/en/index.php>
 - Taiwan Railway Admission: <https://www.railway.gov.tw/en/index.aspx>
 - Taiwan High Speed Rail: https://www.thsrc.com.tw/index_en.html
 - Taoyuan City You Bike: <https://tycg.youbike.com.tw/home>
- ✧ EasyCard: You can use easy card to take bus, train, and rent a You Bike.
EasyCard Website: <https://www.easycard.com.tw/en/>

VI. Activities

Many kinds of activities will be held during the semester – welcome, farewell, folk festivals parties, and cultural trip. Information will be announced through email and OIA website.

VII. Estimate Living Cost

- ◇ It depends on what kind of accommodation you live in. The total monthly budget is between NT\$10,000~15,000. The following prices should also help:
 - McDonald’s Big Mac: NT\$120
 - Lunch Box: NT\$80~100
 - 600 ml mineral water: NT\$20

VIII. Standard Scores in the Transcript

The best academic achievement score for undergraduate students and graduate students is 100. 60 is a passing score for undergraduates and 70 for graduates.

Numeric Grade	93	88	82	78	75	72	68	65	62	50
Letter Grade	A+	A	A-	B+	B	B-	C+	C	C-	D

PART 8: Appendix

I. Location of NCU

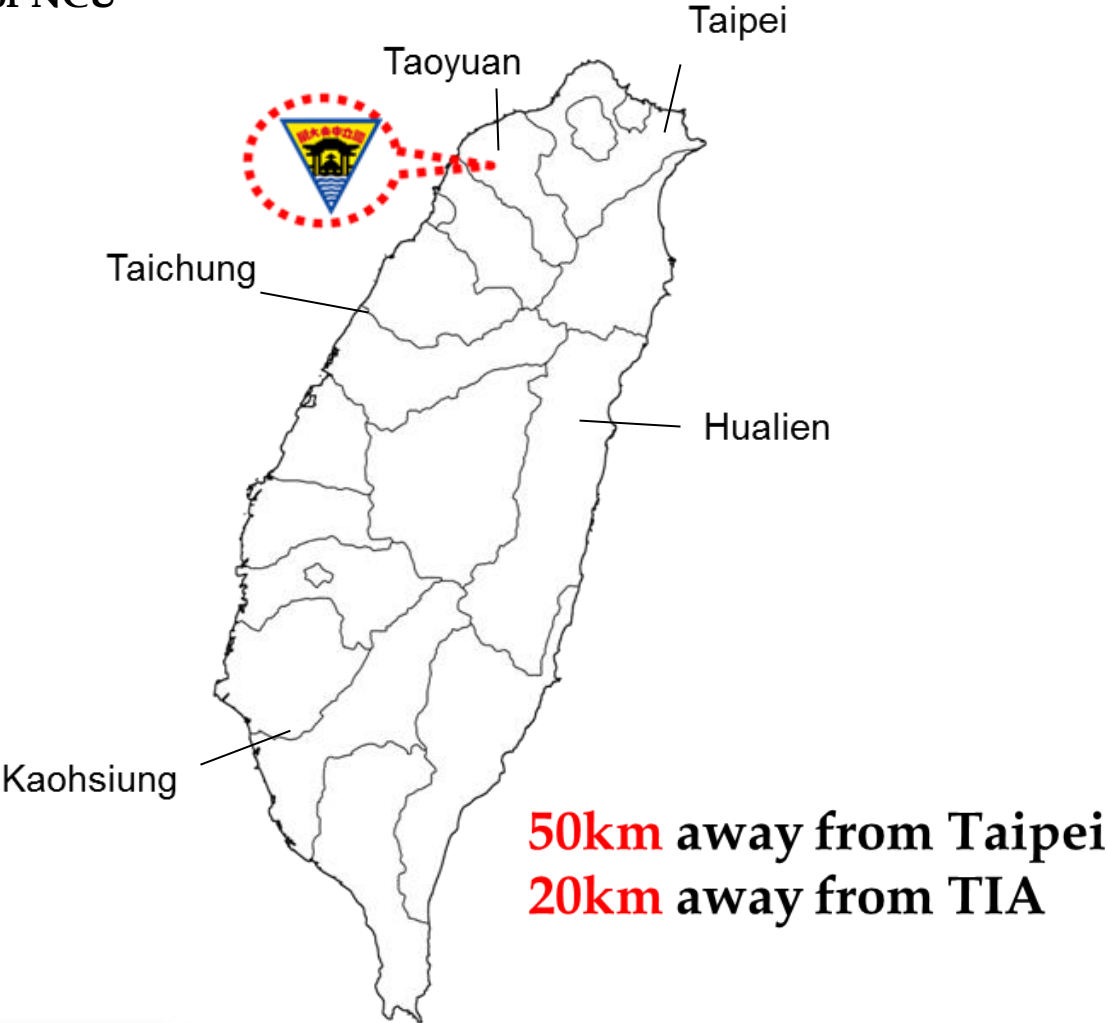

II. Units in NCU

These are some units at NCU you should know:

Unit	When you may need it	Location	Office Hour
Office of International Affairs	Degree student affairs	1 st floor, Center of Innovative Incubator	8:00am-5:00pm, Monday to Friday
http://oia.ncu.edu.tw/index.php			
Cashier	Payment Internet Card Purchasing	1 st floor, Administration Building	8:00am-5:00pm, Monday to Friday
Registry Office	Registration, student ID, proof of enrollment	3 rd floor, Administration Building	8:00am-5:00pm, Monday to Friday
Section of Curriculum	Academic performance and graduation credits	3 rd floor, Administration Building	8:00am-5:00pm, Monday to Friday
Library	Borrow and return books, searching for thesis and journals	Library	Sunday~Friday 8:00~23:00 Sat.:8:00~17:00
https://www.lib.ncu.edu.tw/en/			
Computer Center	Use computers	Computer Center	Monday~Friday 8:00~23:00 weekends and holiday: 9:00~16:00
Health Center	Emergent medical treatment, outpatient service, and traumatic medical treatment	1 st floor, Chung-Cheng Library	8:00am-5:00pm, Monday to Friday
Post Office	Deposit and withdraw money	Post Office	8:30am-5:00pm, Monday to Friday

● **Campus Emergency Phone Call: 03-2805666 (24 hours)**

III. Building Symbols in NCU

(<http://pdc.adm.ncu.edu.tw/Course/course/building.htm>)

大樓代碼 Building Symbol	大樓名稱 Building
A	文學館大樓 Liberal Arts Building I
C2	文學二館大樓 Liberal Arts Building II
E	工程一館(土木工程學系) Engineering Building 1(Department of Civil Engineering)
E1	工程二館(資電學院) Engineering Building 2(College of Electrical Engineering & Computer Science)
E2	機械館大樓 Engineering Building 3 (Mechanical Engineering Building)
E3	環工化工館大樓 Engineering Building 4 (Environmental & Chemical Engineering Building)
E4	機電實驗室 Engineering Building 4
E5	大型力學實驗室 Experiment Center for Civil Engineering
E6	工程五館大樓 Engineering Building 5(College of Engineering)
H2	理學院教學館(原普化實驗大樓) Science Teaching Building
I	志希館大樓 Zhi-Xi Hall (School of Management)
I1	管理二館 Management Building 2
LS	人文社會科學大樓 Humanities and Social Sciences Building
IL	國鼎光電大樓 Kwoh-Ting Optoelectronics Building
L3	國鼎圖書資料館 K. T. Lee Library
M	鴻經館大樓 Hong-Jing Hall
O	綜合教學大樓(語言中心) General Education Building(Language Center)
R2	遙測中心 Research Center Building 1
S	科學一館 Science Building 1(College of Earth Science)
S1	科學二館 Science Building 2(College of Science)
S2	科學三館 Science Building 3
S4	科學四館 Science Building 4
S5	科學五館 Science Building 5
YH	體育館(依仁堂)Office of Physical Education (Yi-Reng Hall)
HK	客家學院大樓 Hakka Studies building

IV. Other Units you may want to know in Taiwan

Bureau of Consular Affairs, Ministry of Foreign Affairs

<http://www.boca.gov.tw>

National Immigration Agency

<http://www.immigration.gov.tw>

Tourism Bureau

<http://eng.taiwan.net.tw/>

Taiwan Taoyuan International Airport

<http://www.taoyuan-airport.com>

Taoyuan Police Department

<https://www.typd.gov.tw/>

Bureau of National Health Insurance

<http://www.nhi.gov.tw/>

Taiwan Railways Administration

<http://www.railway.gov.tw>

Taiwan High Speed Rail

<http://www.thsrc.com.tw>

Taipei Metro

<http://english.trtc.com.tw/>

National Palace Museum

<http://www.npm.gov.tw/>

Living in Taiwan

<https://www.immigration.gov.tw/np.asp?ctNode=36879&mp=2>